

Pareto

Aluminum Systems









**ALFO**<sup>TM</sup>

**Aluminum Flooring System**

[www.paretoas.com](http://www.paretoas.com)

## B Pillar Grab Rail – Installation Guide

#	Description	Picture	#	Description	Pictures
1	Marker		4	Oscillating Cutting Machine	
2	Drilling Machine		5	4 mm Allen Key	
3	8 mm - Drilling Bit		6	1.25" Hole Cutter	 <p data-bbox="1860 1263 2471 1306">These items are not included in the package</p>

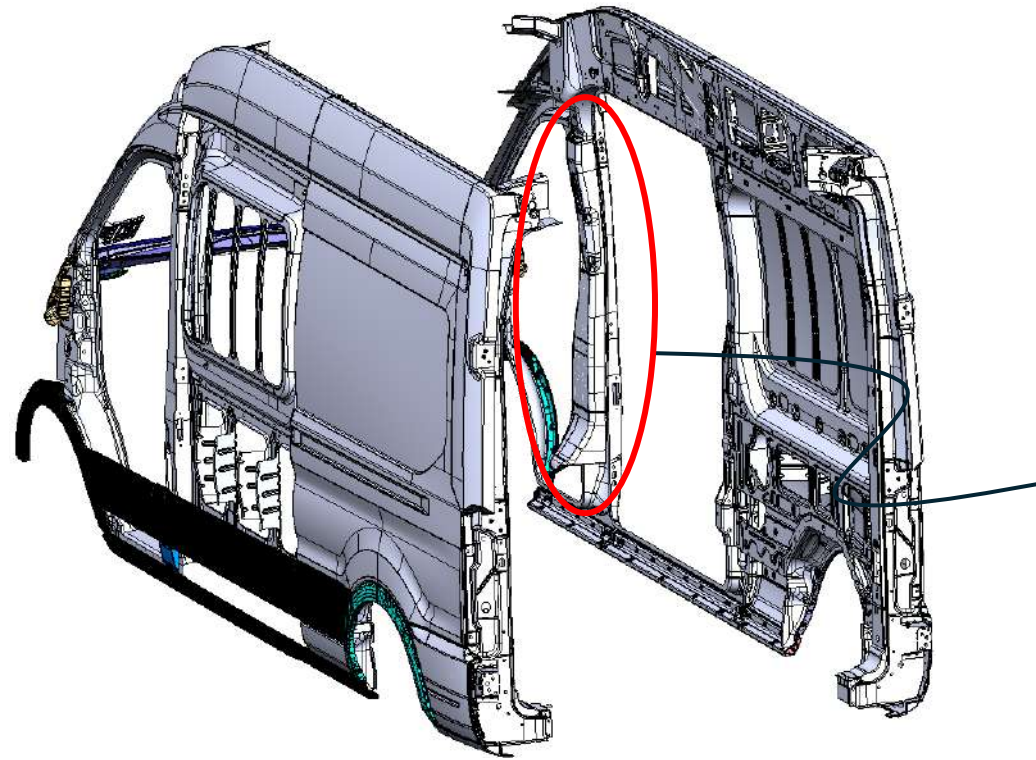

Grab Handle  
(Plastic)

Door Rubber Seal



**STEP 1:** Remove old grab handle (Plastic) & the door rubber seal (Trim) from the Passenger side B Pillar to mark the hole for drilling.

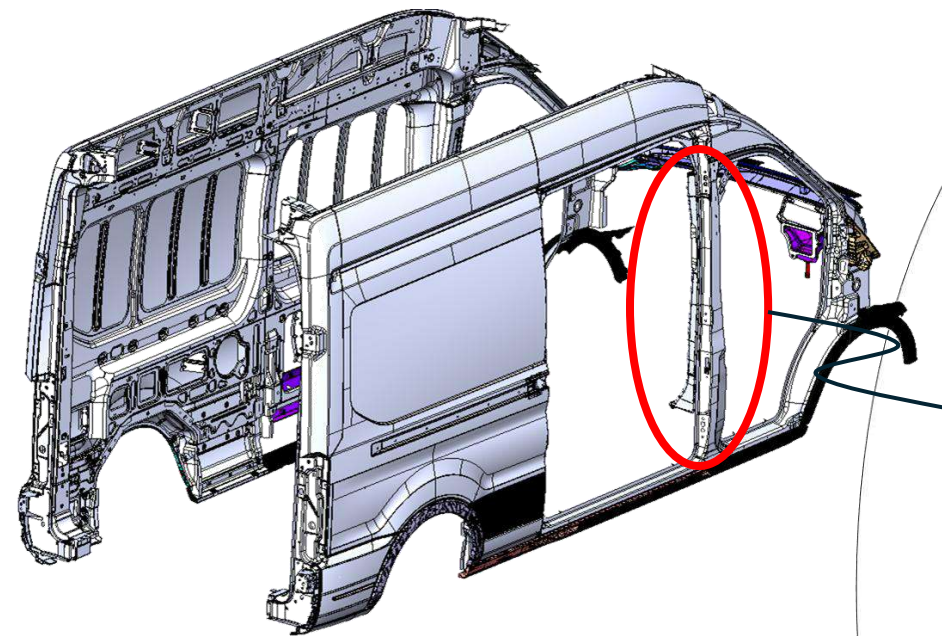

**STEP 2 :** See through the gap between the plastic part and OEM B Pillar to identify the M6 weld nut that is welded along with the B Pillar & Mark the center point of the nut on the Plastic part.

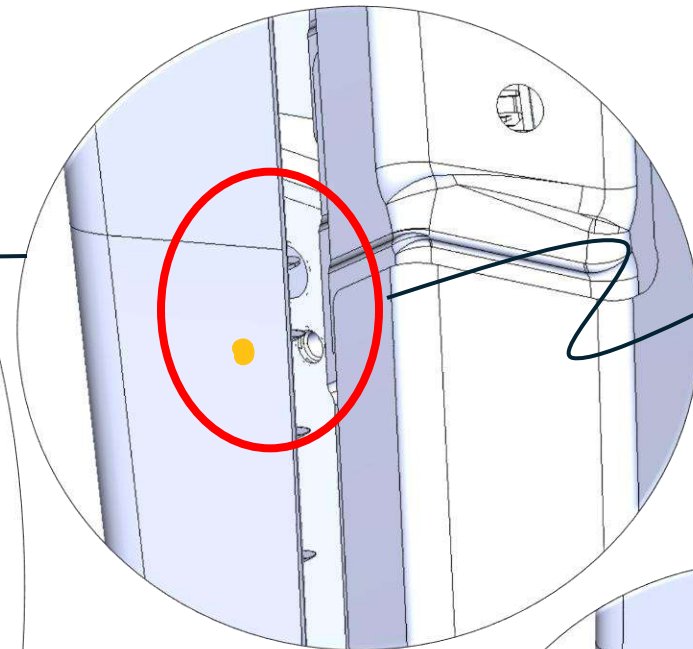
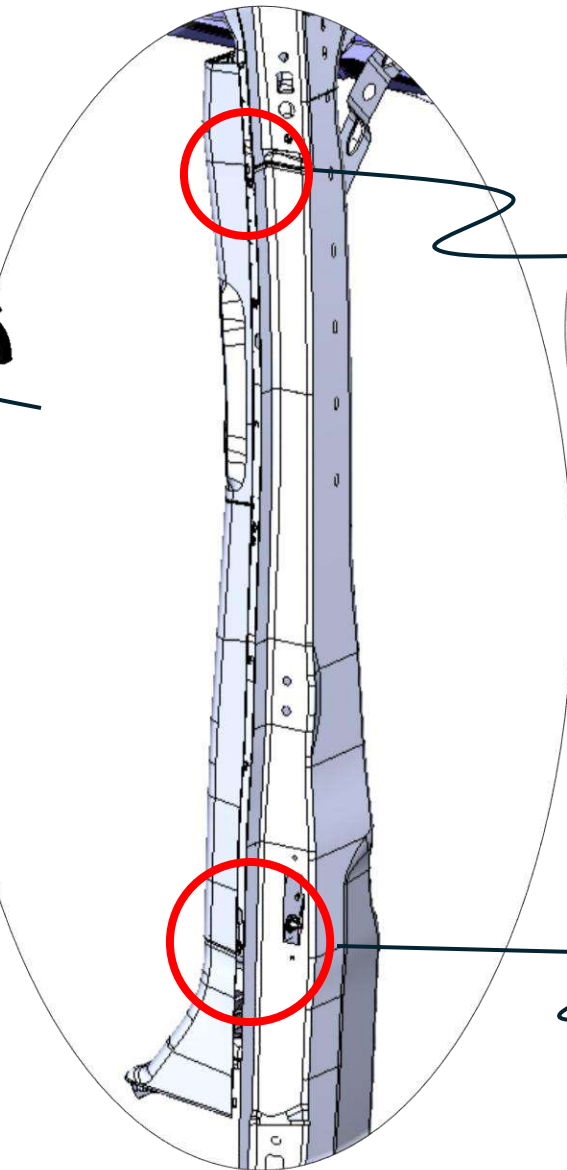

Identify the M6 weld nut below the first hole & Mark on the plastic part

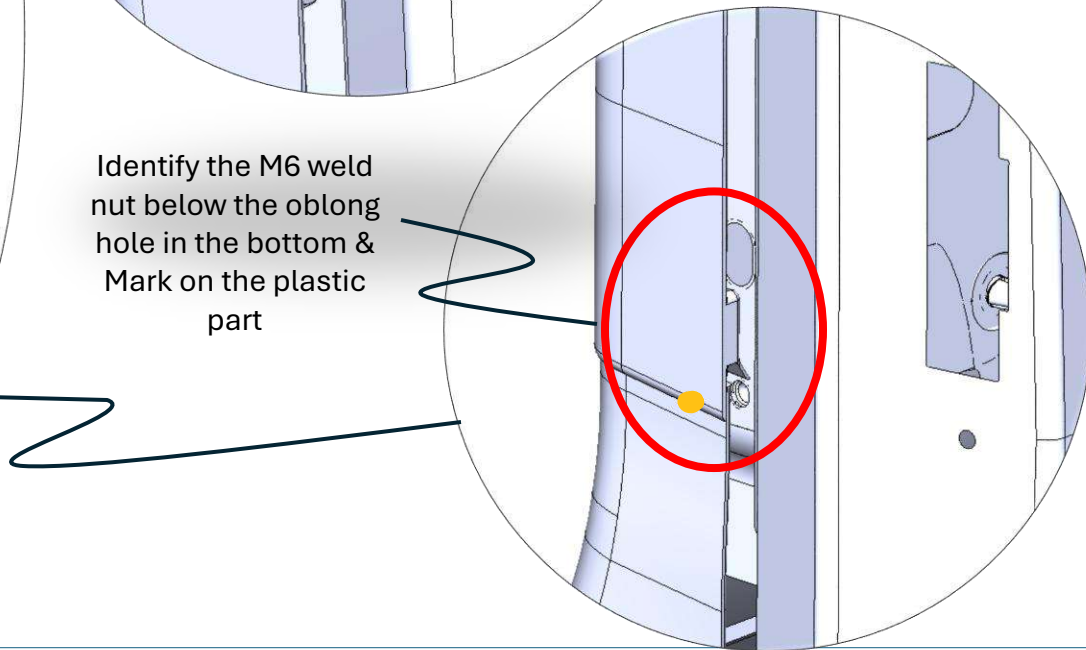

Identify the M6 weld nut below the oblong hole in the bottom & Mark on the plastic part

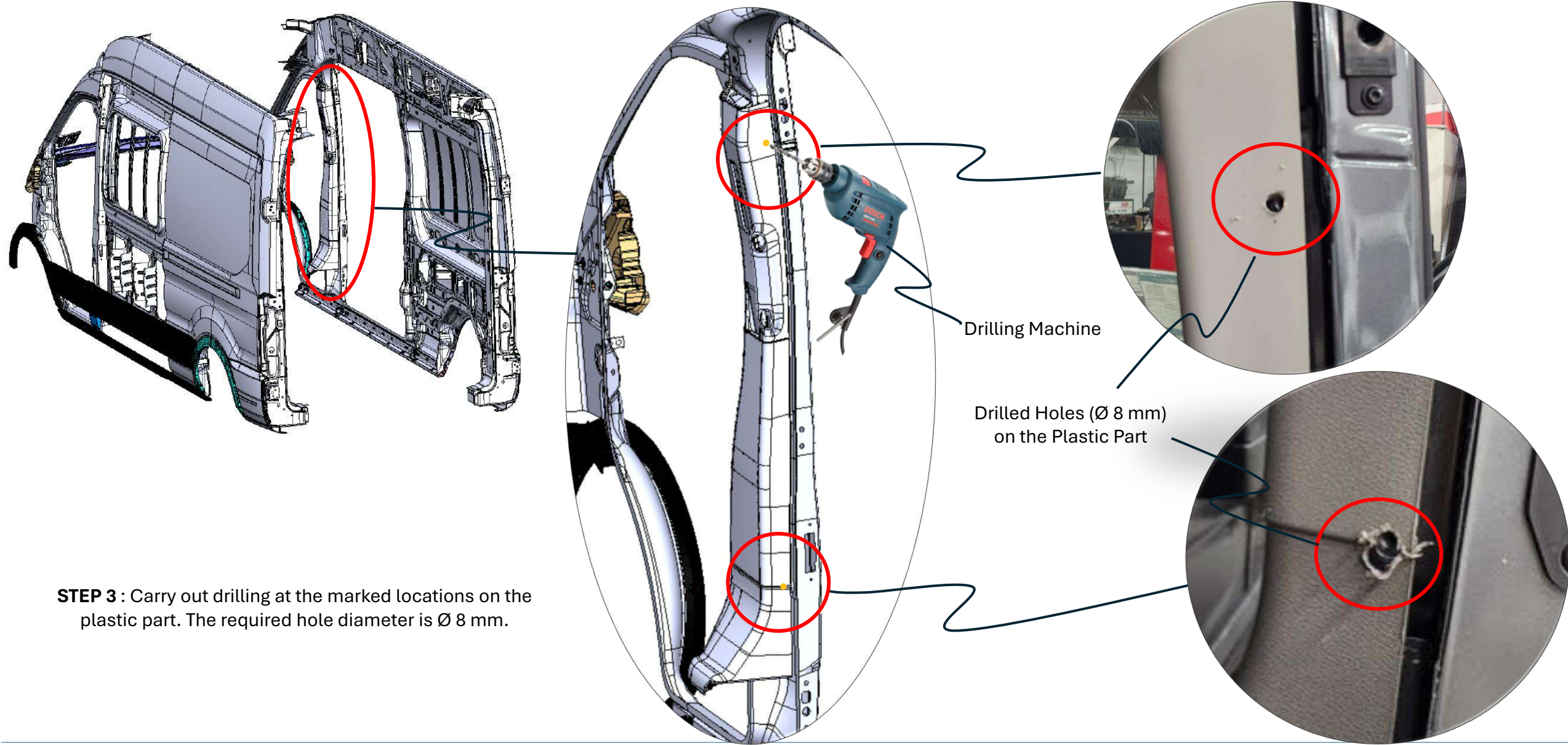

**STEP 3 :** Carry out drilling at the marked locations on the plastic part. The required hole diameter is Ø 8 mm.

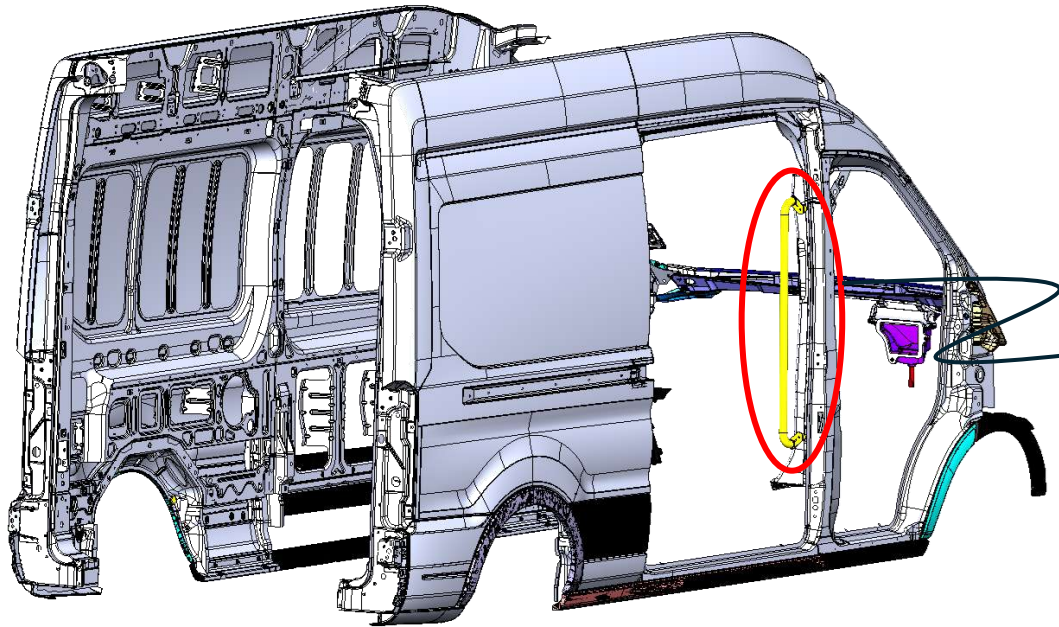

**STEP 4 :** Bring the B Pillar Grab Rail and Connect with the weld using M6 x 75 mm - Hex Head Bolt (2 No's) to mark on the plastic part to be cut.

Mark the profile of the spacer and gusset on plastic part & then remove the Bolt & Grab Rail.

**Note: Do the same for the Bottom Portion.**

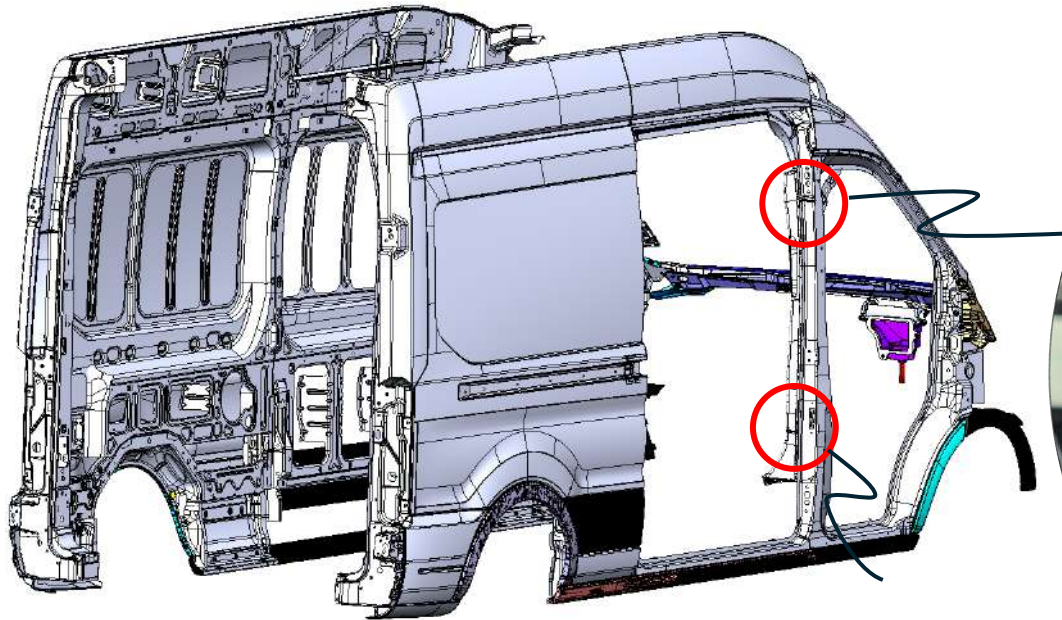

Oscillating Cutting Machine

After Cutting



**STEP 5 :** Use the Drilling machine & 1.25" hole saw cutter to cut the plastic part where the round mark lines are there.

Then use the oscillating cutter to cut the small notch portion.



1.25" hole saw cutter

**Note: Do the same for the Bottom Portion.**

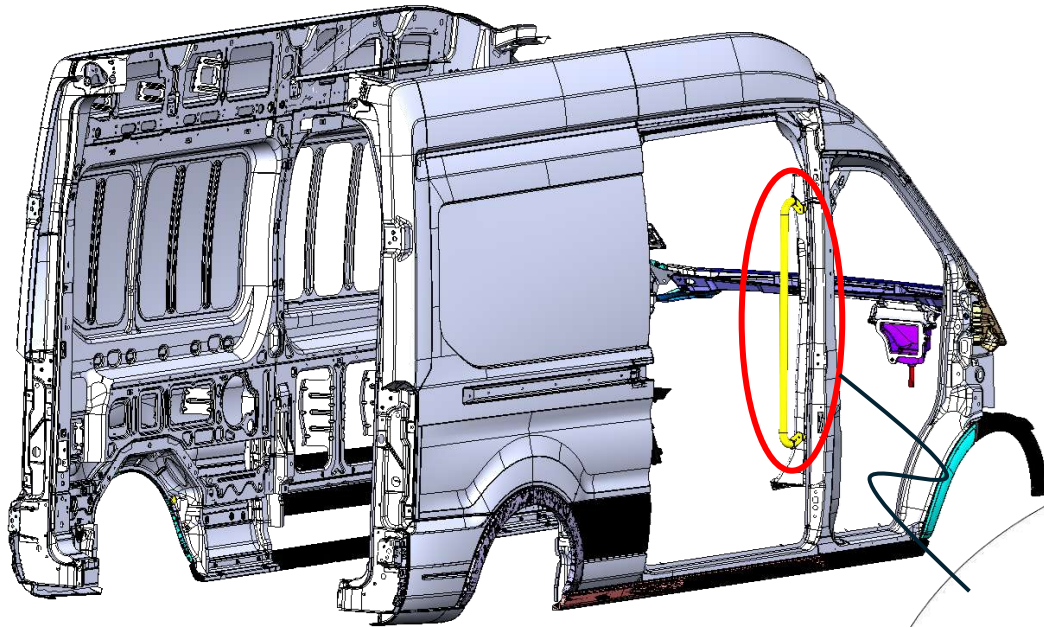

M6 x 50 mm – Button Head Bolt (2 No's) & M6 Flat Washer (2 No's)

**STEP 6 :** After Cutting the plastic part, Put the Grab rail in its place and tighten it with the M6 weld nut using M6 x 50 mm Button Head Bolt (2 No's) & M6 Flat Washer (2 No's).

Then put the door rubber seal back.

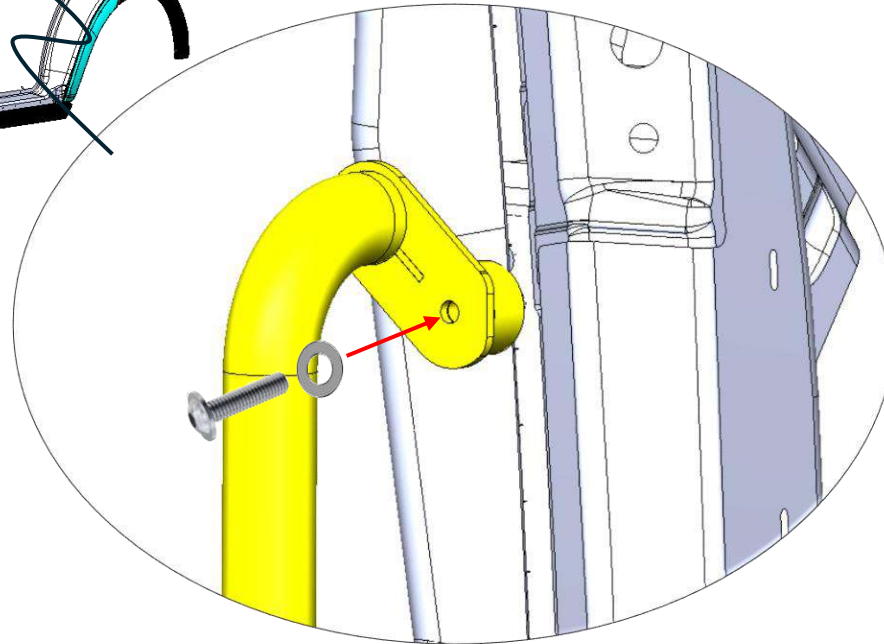

**Note: Do the same for the Bottom Portion.**