

Pareto

Aluminum Systems







ALFOTM

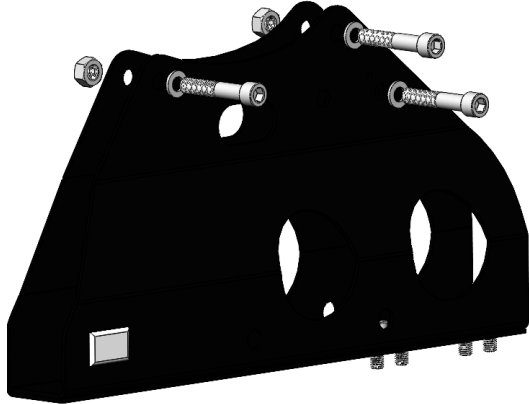
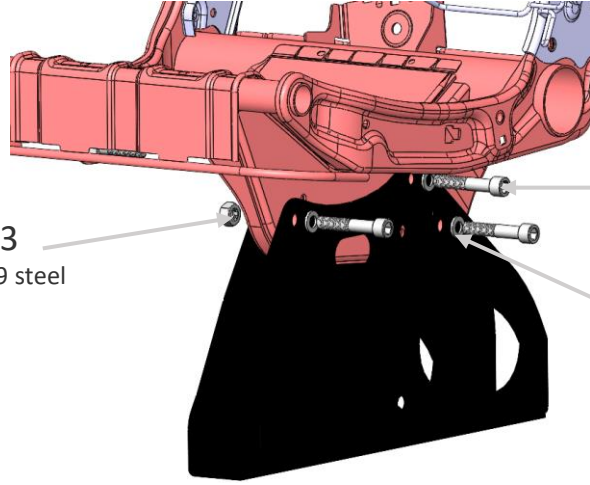

Aluminum Flooring System

www.paretoas.com

Ford D Pillar Seat
installation guide

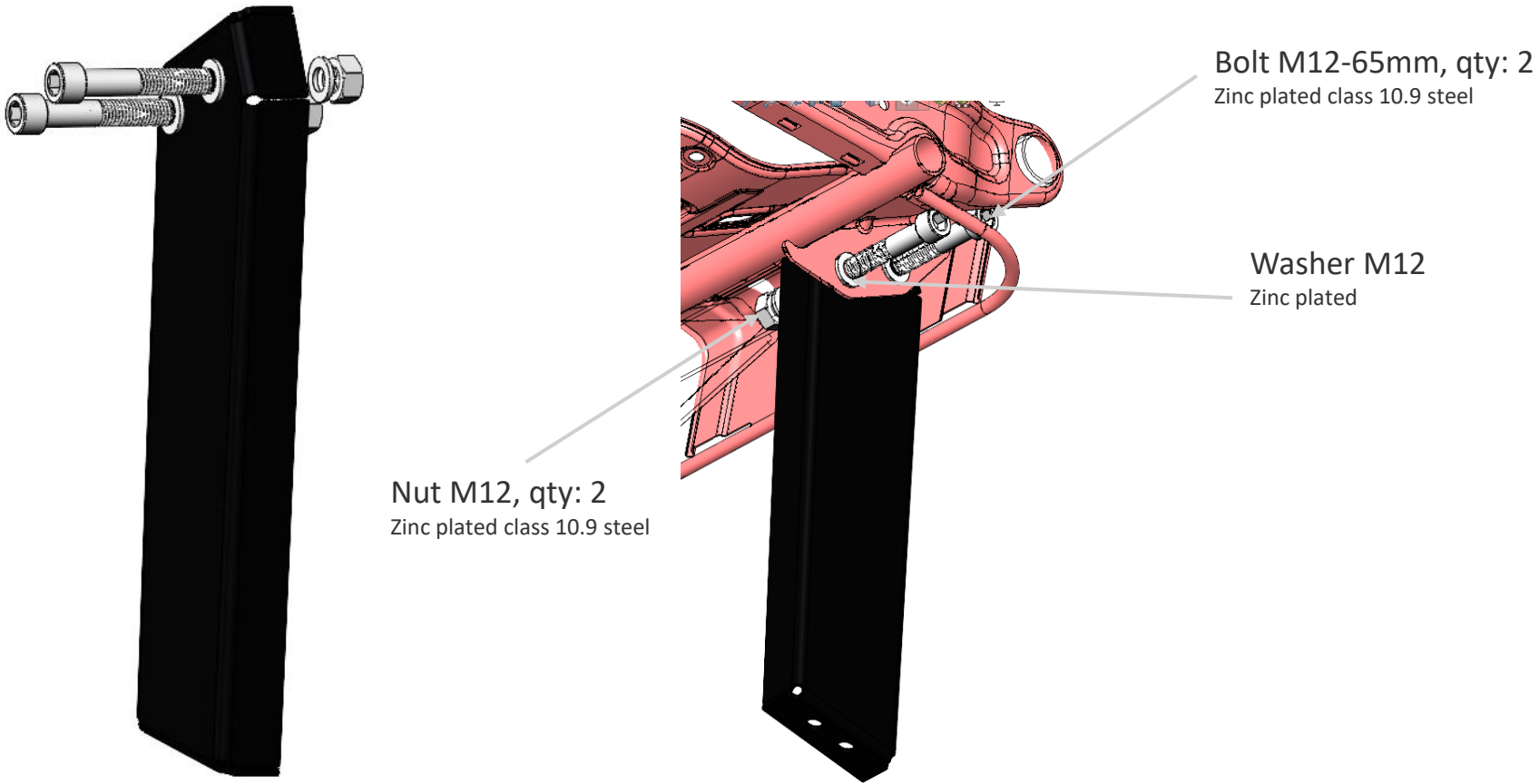
#	Install Steps	Description, Pictures and figures	
1	<p>Uninstall the factory seat legs form the OEM seat</p> <p>Discard both the seat legs, rear bracket and washer bracket, as shown in the image.</p>	 <p>Seat legs</p> <p>Rear bracket</p>	 <p>Washer bracket</p> <p>Retain the factory bolt and discard the bracket</p>
2	<p>Attach the F40 - seat leg</p> <p> Apply 55Nm torque with all M12 bolts</p>	 <p>F40</p>	 <p>Bolt M12-65mm, qty: 3 Zinc plated class 10.9 steel</p> <p>Nut M12, qty: 3 Zinc plated class 10.9 steel</p> <p>Washer M12, qty:3 Zinc plated</p>

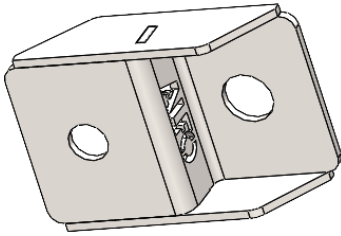
#	Install Steps	Description, Pictures and figures
3	<p>Attach the F50 - seat leg</p> <p> Apply 55Nm torque on all M12 bolts</p>	 <p>F50</p> <p>Bolt M12-65mm, qty: 2 Zinc plated class 10.9 steel</p> <p>Nut M12, qty: 2 Zinc plated class 10.9 steel</p> <p>Washer M12 Zinc plated</p>

#	Install Steps	Description, Pictures and figures
4	<ul style="list-style-type: none">• Attach the F70 -wheel well bracket with the seat bracket using Hex Bolt M12x25.• Attach the seat to D-pillar area as shown using factory bolt with flat washer.	<p data-bbox="1386 154 1888 187">Description, Pictures and figures</p> <div data-bbox="700 335 1039 568"></div> <p data-bbox="835 611 894 639">F70</p> <div data-bbox="1447 258 1742 586"></div> <p data-bbox="1931 375 2099 404">Seat bracket</p> <div data-bbox="1824 634 2346 1219"></div> <p data-bbox="1256 818 1658 961">Use Hex Bolt M12x25 bolt, flat washer and M12 nylon lock nut to assemble the Seat bracket and with F70 bracket.</p> <p data-bbox="1753 1246 2423 1275">Re-use the factory bolt with M12 fender flat washer</p>

#	Install Steps
---	---------------

Description, Pictures and figures

5

Attach F40 leg with the floor and fasten the bolt with hand

 Do not torque the fasteners

Bolts M10-30mm, Qty-06
Zinc plated class 10.9 steel

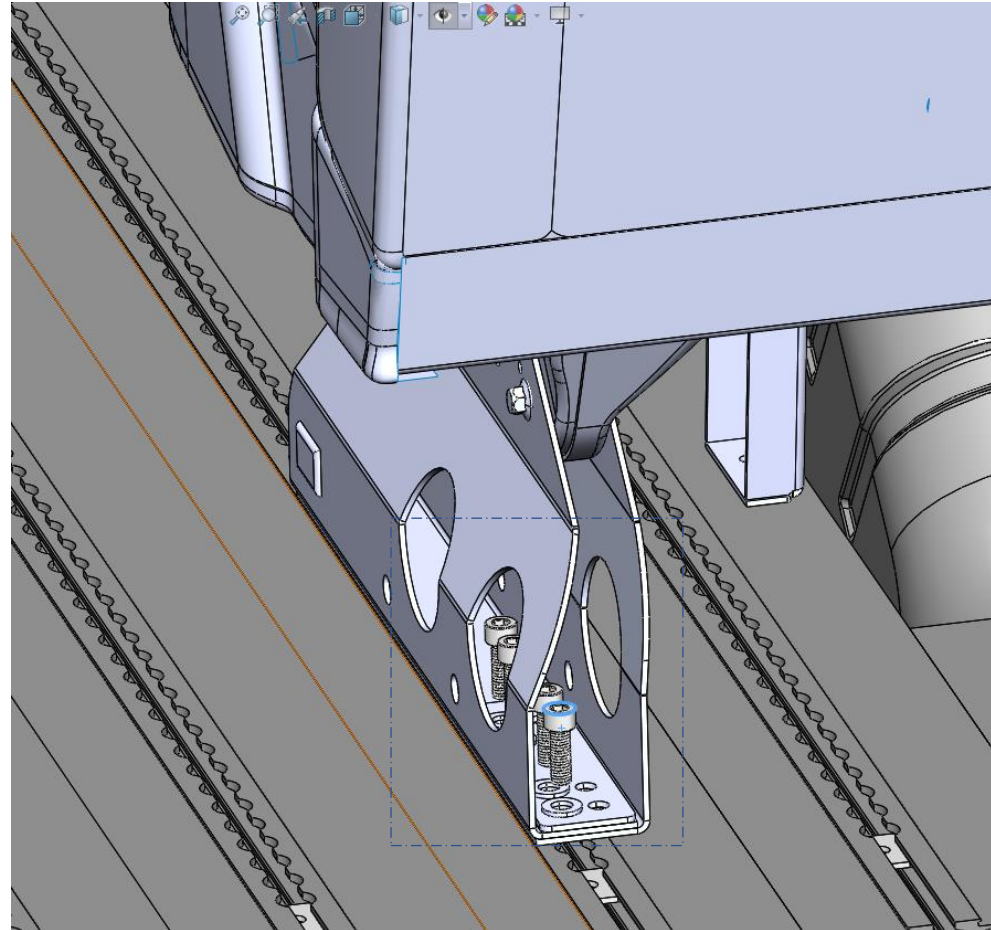

Washer M10,
Qty-12
Zinc plated

Manual
Foot

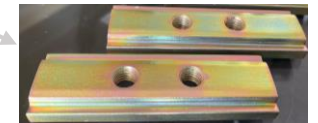
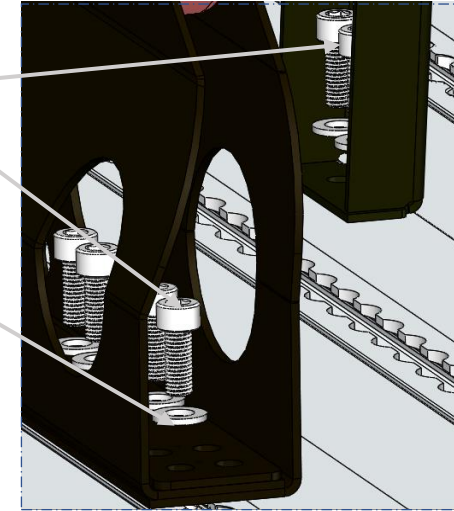

#	Install Steps
---	---------------

Description, Pictures and figures

6	Mark $\varnothing 13.5\text{mm}$ on the floor
---	---

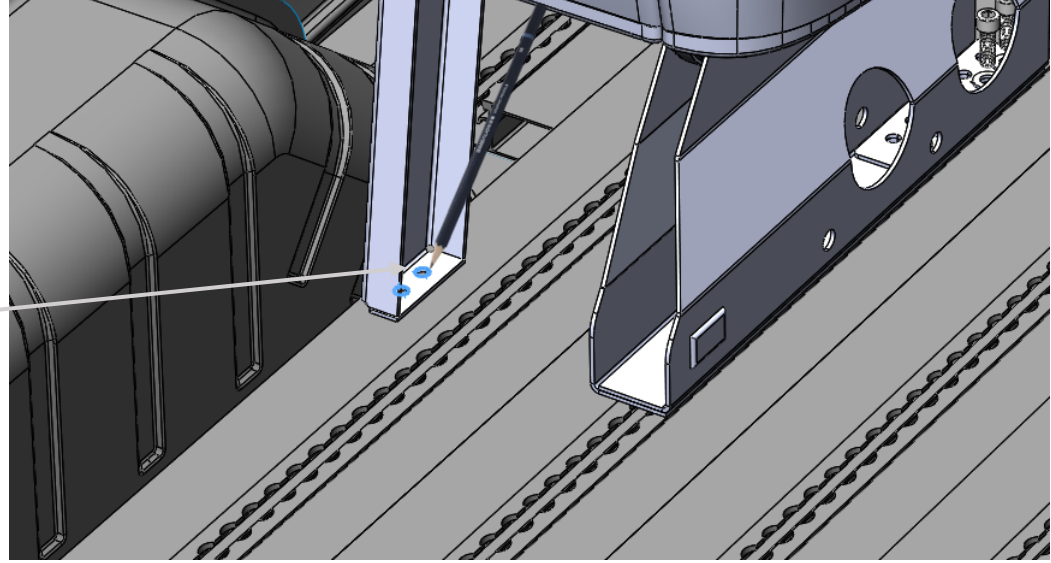
Mark the circle by taking F50 leg hole Position Reference	
---	---

7	Remove the seat from the installed location
---	---

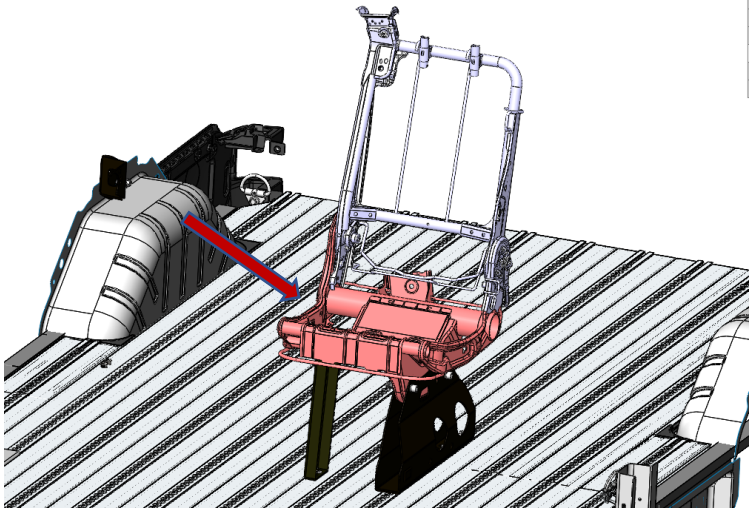
	
---	--

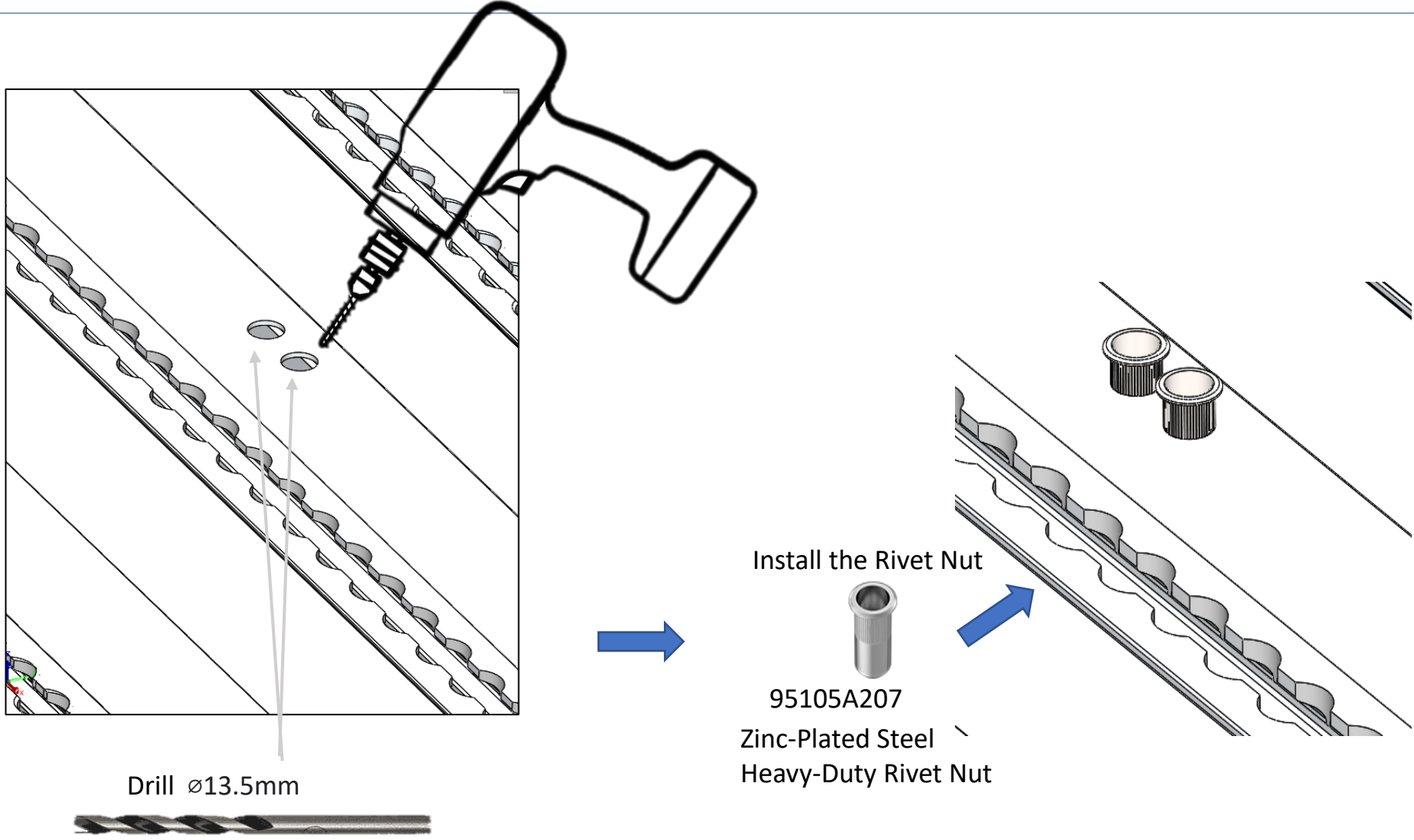
#	Install Steps	Description, Pictures and figures
8	Drill $\varnothing 13.5\text{mm}$ on the floor for installing F50 leg	<p data-bbox="1386 154 1888 189">Description, Pictures and figures</p>  <p data-bbox="843 1189 1072 1225">Drill $\varnothing 13.5\text{mm}$</p> <p data-bbox="1651 901 1956 936">Install the Rivet Nut</p> <p data-bbox="1633 1079 1964 1210">95105A207 Zinc-Plated Steel Heavy-Duty Rivet Nut</p> <p>The diagram illustrates the installation process in two stages. On the left, a power drill is shown drilling a hole into a metal floor plate. Two arrows point to the newly drilled holes, with the label 'Drill $\varnothing 13.5\text{mm}$' below them. A drill bit is shown at the bottom. A blue arrow points to the right, where the second stage is shown. A single rivet nut is shown with the label '95105A207 Zinc-Plated Steel Heavy-Duty Rivet Nut'. Another blue arrow points to the right, where two rivet nuts are shown being inserted into the holes of the floor plate. The text 'Install the Rivet Nut' is positioned above this final step.</p>

#	Install Steps	Description, Pictures and figures
9	<p>Tighten all the Bolts</p> <p> Use 55N-m torque to M10 bolts, Qty-06</p>	<p data-bbox="1386 154 1888 189">Description, Pictures and figures</p> 