

Pareto

Aluminum Systems



Ford Double Seat Installation on ALFO Floor

ALFOTM

Aluminum Flooring System

www.paretoas.com



Ford Double Seat: OEM Seat Leg Installation

Step 1: Uninstall the Factory legs and discard them.

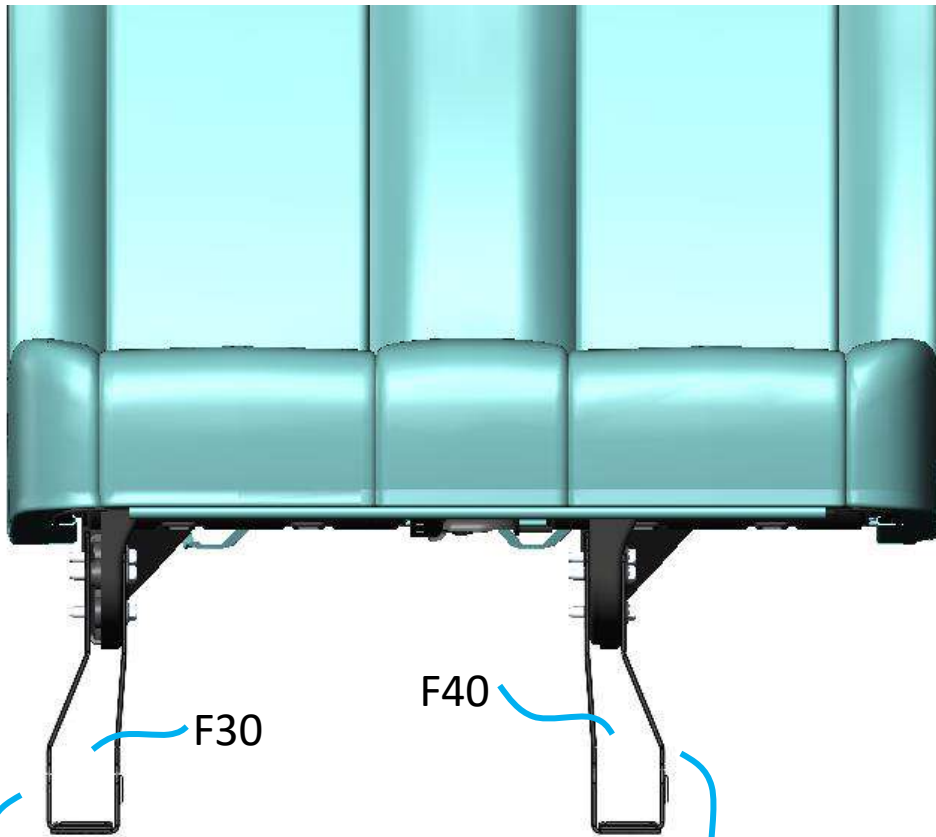

The legs should be attached in such a way that the leg protrude towards inside

Step 2: install the OEM Seat Legs

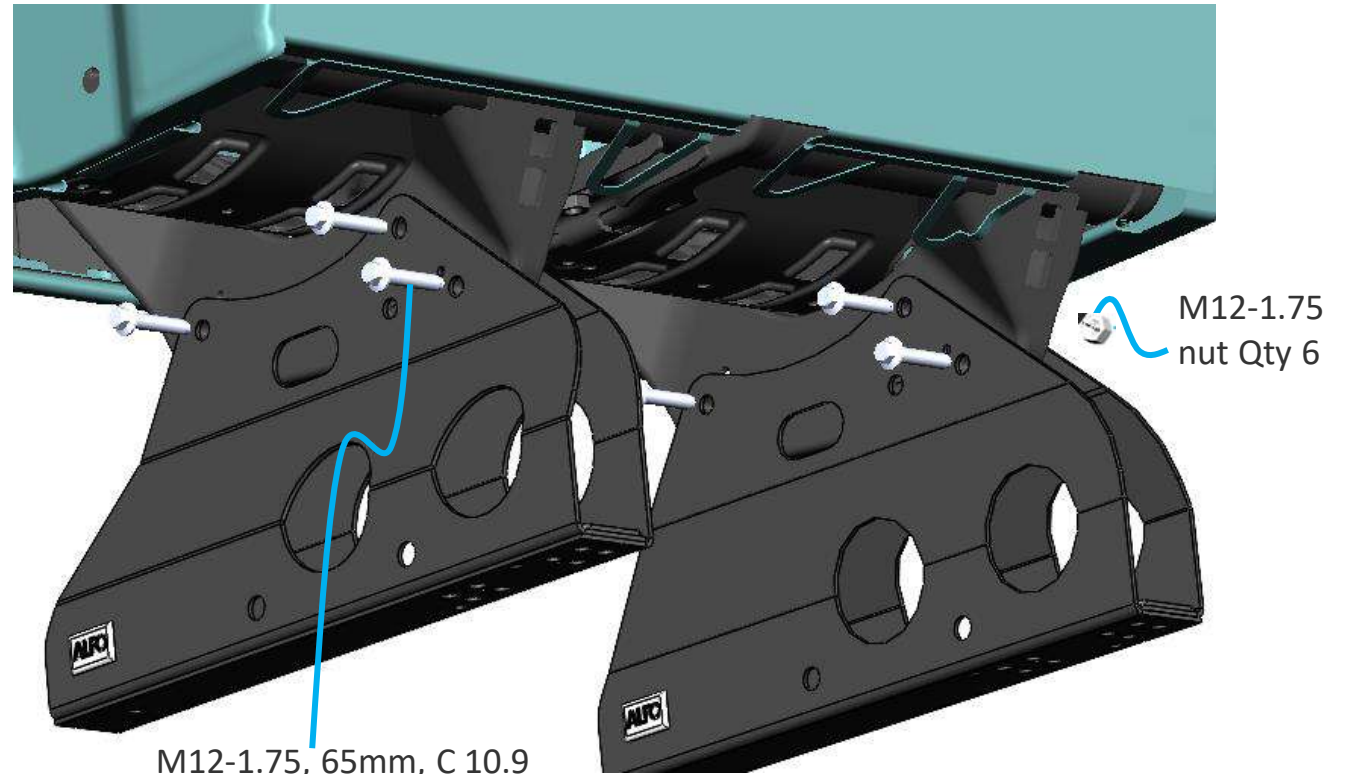

M12-1.75, 65mm, C 10.9
Zinc plated bolts
Qty 6
Torque Required: 55Nm



View from the Front

Step 3: Insert the manual foot and move them to the desired location of seat installation

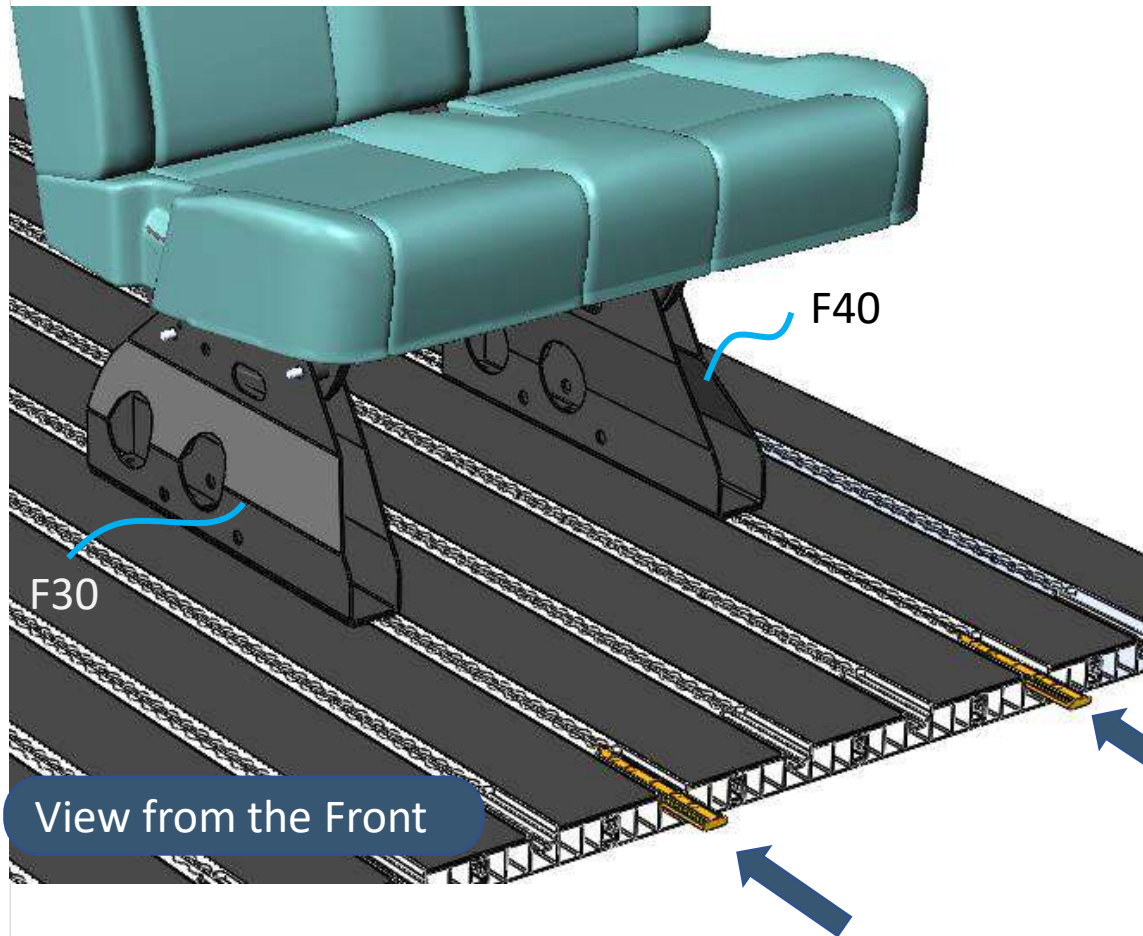

Step 4: Attach the 4 Qty bolts with Washer per leg to the manual foot

