

# Pareto

Aluminum Systems







# ALFO<sup>TM</sup>



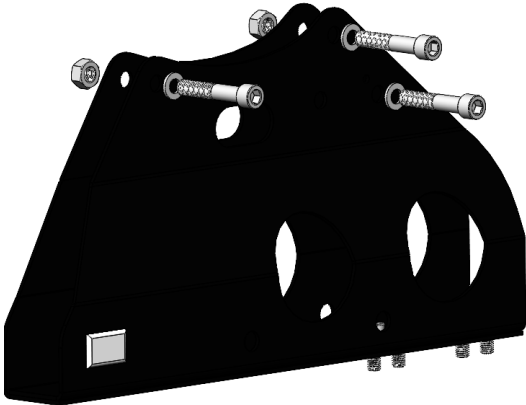
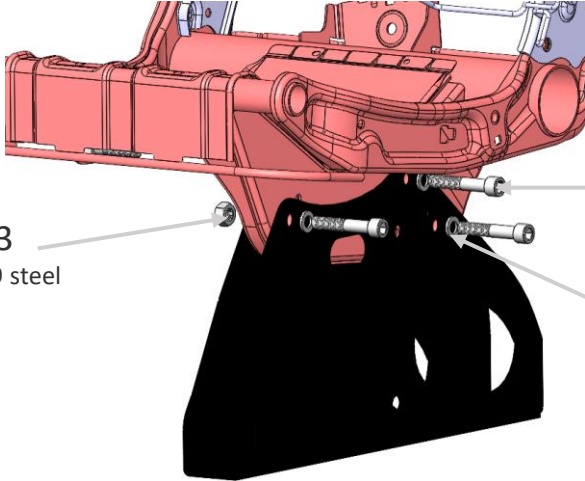

**Aluminum Flooring System**

[www.paretoas.com](http://www.paretoas.com)

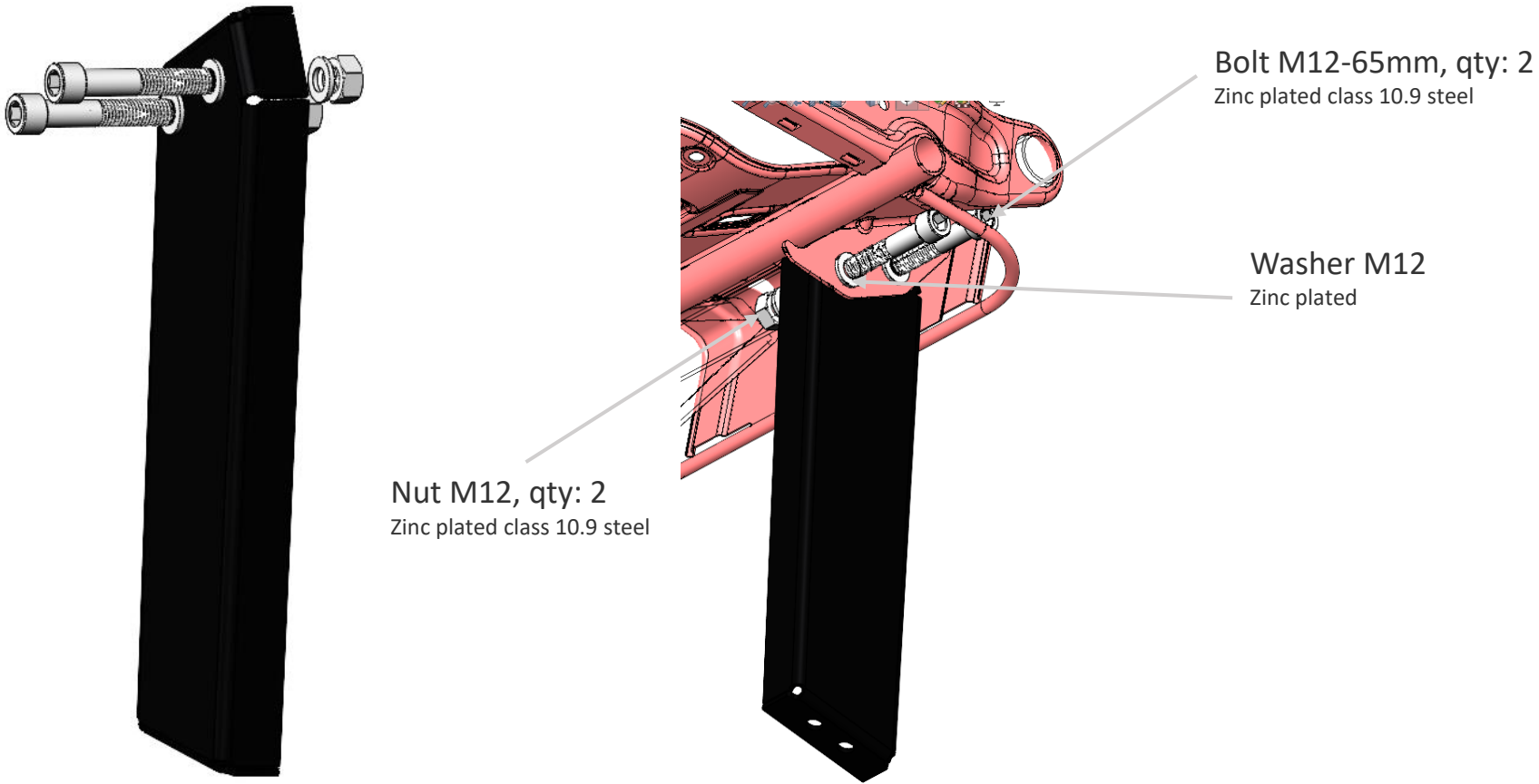
Seat over wheel well  
installation guide

#	Install Steps	Description, Pictures and figures	
1	<p>Uninstall the factory seat legs form the OEM seat</p> <p>Discard both the seat legs, rear bracket and washer bracket, as shown in the image.</p>	 <p>Seat legs</p> <p>Rear bracket</p>	 <p>Washer bracket</p> <p>Retain the factory bolt and discard the bracket</p>
2	<p>Attach the F40 - seat leg</p> <p> Apply 55Nm torque with all M12 bolts</p>	 <p>F40</p>	 <p>Nut M12, qty: 3 Zinc plated class 10.9 steel</p> <p>Bolt M12-65mm, qty: 3 Zinc plated class 10.9 steel</p> <p>Washer M12, qty:3 Zinc plated</p>

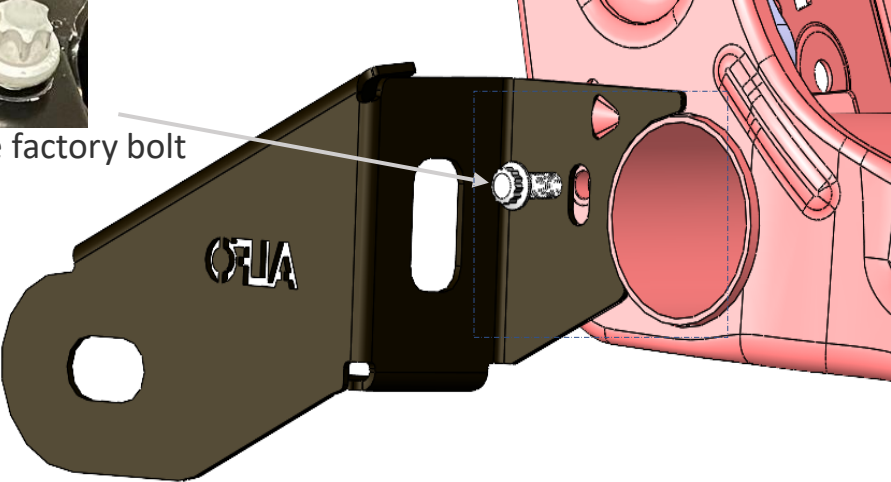
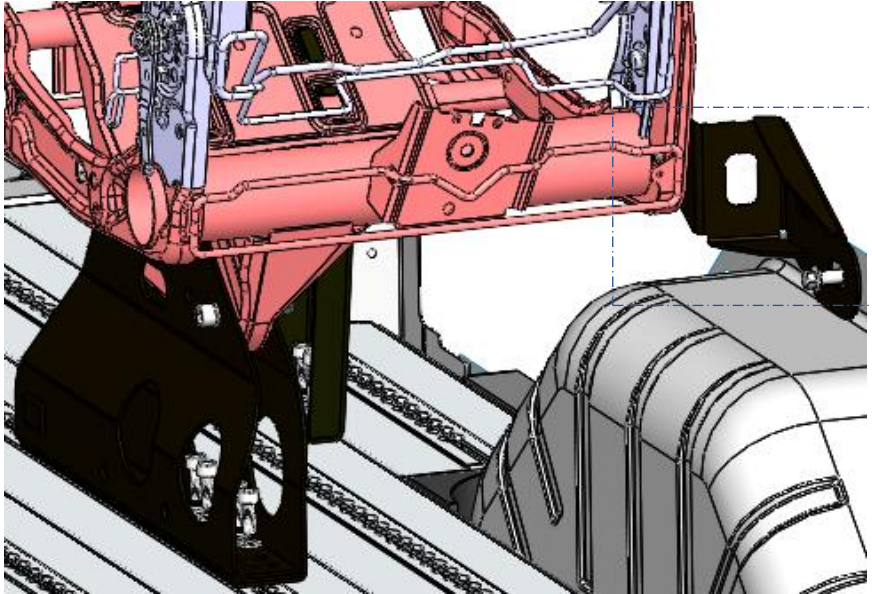
#	Install Steps	Description, Pictures and figures
3	<p>Attach the F50 - seat leg</p> <p> Apply 55Nm torque on all M12 bolts</p>	 <p>F50</p>

#	Install Steps	Description, Pictures and figures
4	Attach the F60 -wheel well bracket	<p data-bbox="1386 154 1888 189">Description, Pictures and figures</p>  <p data-bbox="784 654 843 689">F60</p>  <p data-bbox="1386 372 1727 408">Re-use the factory bolt</p> 
5	Attach the seat to wheel well area Using factory bolt with flat washer	  <p data-bbox="1747 1300 2532 1336">Re-use the factory bolt with M12 fender flat washer</p>

#	Install Steps
6	<p>Move the Ford seat for installation over the wheel well area hand tighten the fasteners</p> <p> Do not torque the fasteners</p>

**Description, Pictures and figures**

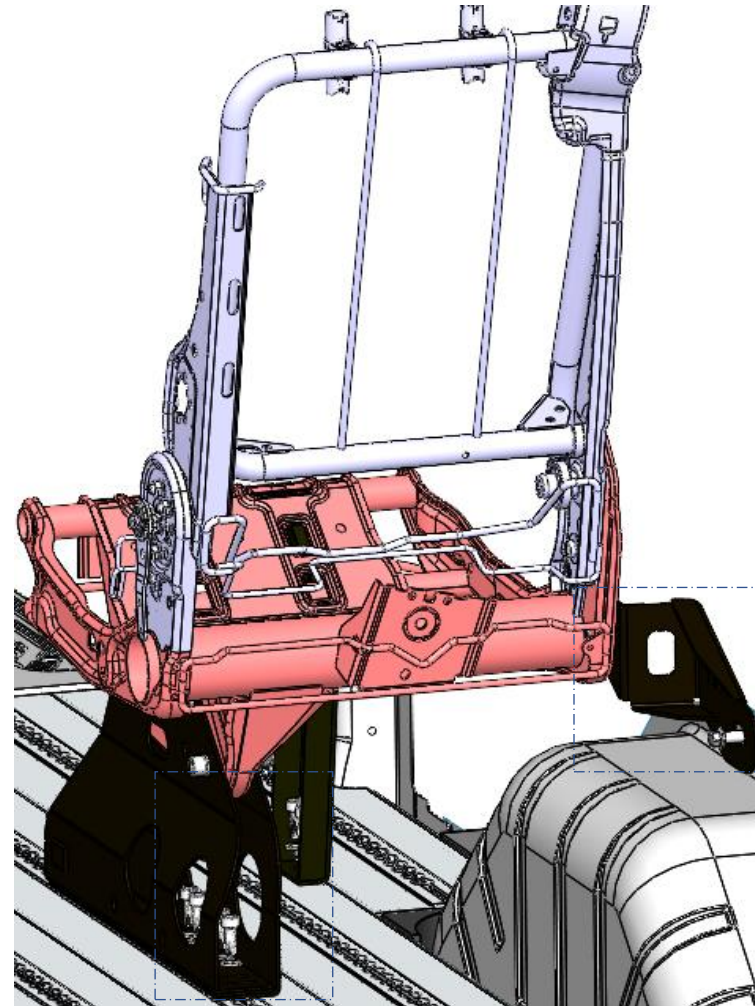

**Bolts M10-30mm, Qty-06**  
Zinc plated class 10.9 steel

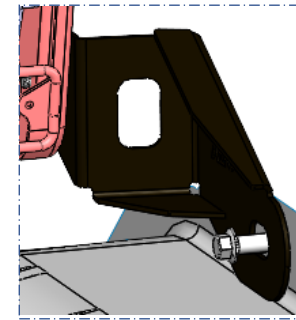

**Washer M10, Qty-12**  
Zinc plated

**Manual Foot**

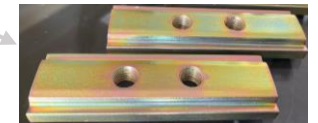
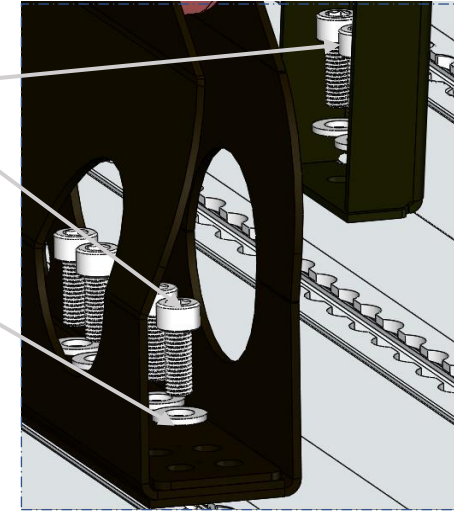

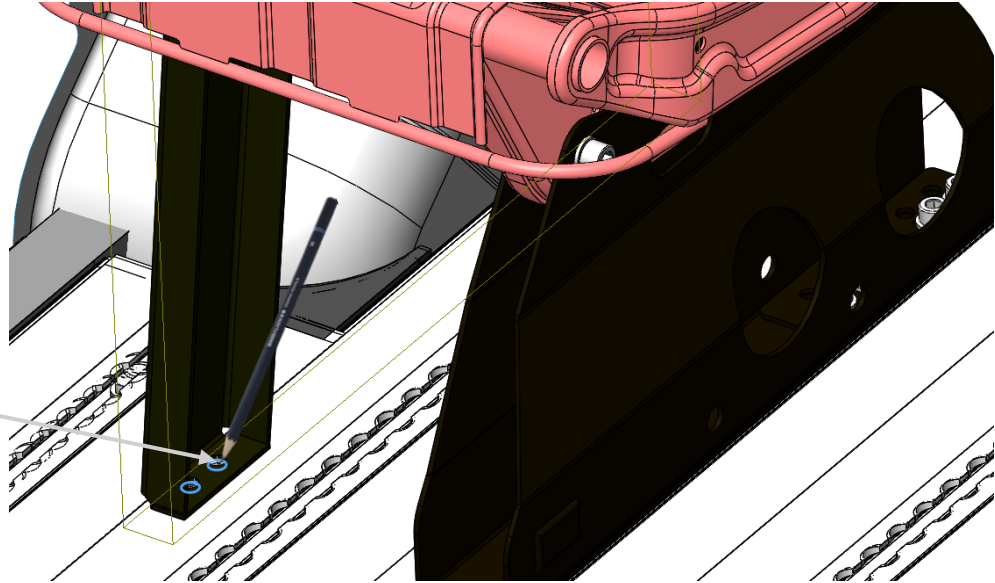
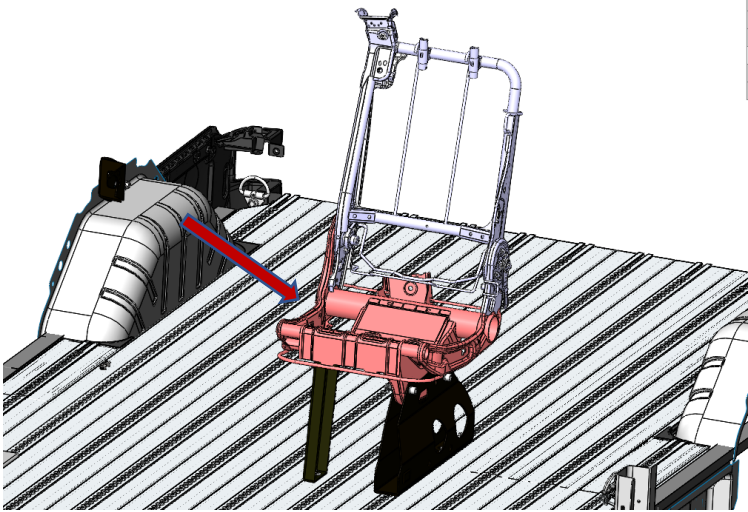
#	Install Steps	Description, Pictures and figures
7	Mark $\varnothing 13.5\text{mm}$ on the floor	<p>Mark the circle by taking F50 leg hole Position Reference</p> 
8	Remove the seat from the installed location	

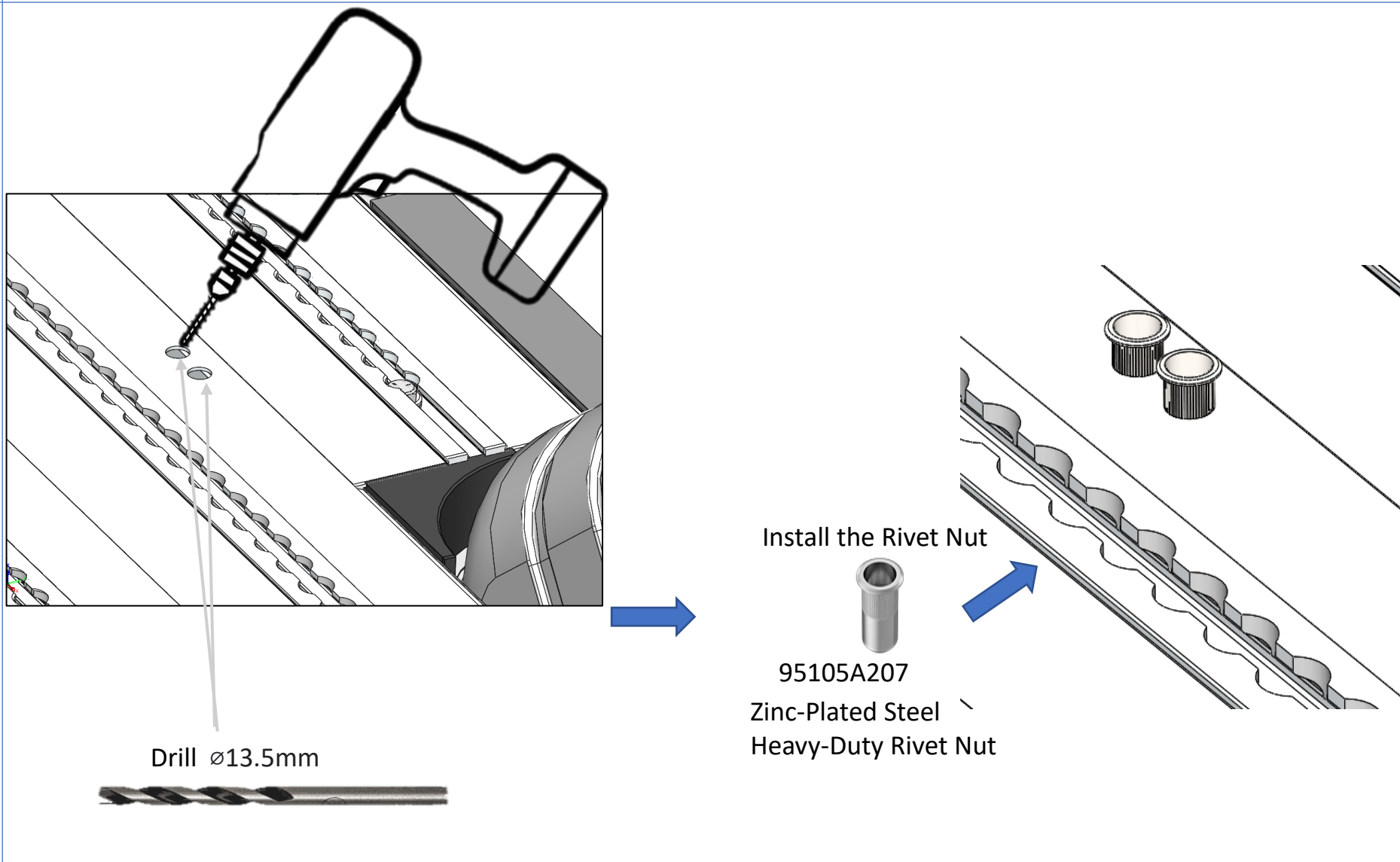
#	Install Steps	Description, Pictures and figures
9	Drill $\varnothing 13.5\text{mm}$ on the floor for installing F50 leg	 <p>The diagram illustrates the installation process in two stages. In the first stage, a hand is shown using a power drill to create a hole in the floor of a vehicle's wheel well. A callout shows a drill bit with the text "Drill <math>\varnothing 13.5\text{mm}</math>". In the second stage, a "95105A207 Zinc-Plated Steel Heavy-Duty Rivet Nut" is being inserted into the hole. A blue arrow points from the first stage to the second. The text "Install the Rivet Nut" is placed above the rivet nut, and another blue arrow points from the rivet nut to the hole in the floor. The rivet nut is shown in two positions: one being inserted and one already seated in the hole.</p>

#	Install Steps
---	---------------

Description, Pictures and figures
-----------------------------------

9 Tighten all the Bolts

 Use 55N-m torque to M10 bolts, Qty-06

